

Vacuum Dehydration Units

MINI WATER VAC & MAXI WATER VAC

The RMF Vacuum Dehydration Units are designated oil purification units which can be applied directly to various types of machine reservoirs. The units dehydrate and clean most types of oil such as lubricating, hydraulic, transformer and switch oils by removing particles, gasses, and water. The purified oil satisfies the most stringent quality requirements, such as stated in the ISO 4406.

Simple operation

The Vacuum Dehydration Units neither remove nor alter oil additives. The water removal process is based on pure vacuum evaporation inside a vacuum chamber at a maximum temperature of 60 °C. Solid particle removal is achieved through a well proven RMF Systems micro filter.

The dehydration units do not require continuous attention whilst operating. Once the dehydration units are connected properly and commissioned, oil purification is a semi-automatic process. The

desired oil temperature can be selected on a thermostat which is included in the integrated heater element of the dehydration units.

Oil supply and removal from the vacuum chamber is a full automatic process which is controlled by a PLC. Overflow of the waste container or tank is protected through a float switch which will shut down the dehydration unit once the maximum level is reached. The only manual action is the emptying of the pre-condenser and waste water container (depending on model).



MINI Water VAC

Water, gas and particle removal

The Vacuum Dehydration Units remove liquid, gas and solid contamination, which are corrosive and contribute to the reduction of machine life. Water, gas and solid particle contamination greatly increase maintenance costs and contribute to unwanted break downs or total machine failures. The Mini Water Vac and Maxi Water Vac offer protection against malfunctions, break downs and total failures. The dehydration units also protect the environment by reducing oil consumption and oil disposal along with its inherent costs and problems.

Benefits

- 1 Efficiently removes water, gas and particulates
- 2 Minimizes corrosion in systems
- 3 Significantly prolongs service life of fluid and system
- 4 Reduces downtime and maintenance costs
- 5 Reduces cost of ownership



MAXI WATER VAC

Steel Industry

Paper Industry

Marine industry (dredgers/thrusters)

Machine tool industry

Mining industry

Tunneling machines



Vacuum Dehydration Units

TECHNICAL SPECIFICATIONS & DIMENSIONS

OVERALL UNIT	MWW	MXWW
Power supply	3 phase	3 phase
Voltage / frequency	230/400 VAC 50 Hz 255/460 VAC 60 Hz	230/400 VAC 50 Hz 255/460 VAC 60 Hz
Total power	2,7 kW	5,4 kW
Dimension inlet	Connection 1" BSP female, minimum hose diameter 3/4", maximum hose length 5 meter	Connection 3/4" BSP female, minimum hose diameter 3/4", maximum hose length 5 meter
Dimension outlet	Connection 1/2" BSP female, minimum hose diameter 1/2", maximum hose length 5 meter	Connection 3/4" BSP female, minimum hose diameter 1/2", maximum hose length 5 meter
Max. back pressure		1 bar
Max. inlet pressure		1 bar
Max. suction height		2 meter
Water discharge	Manual (pre-condenser)	Semi-automatic (pre-condenser)
Weight	130 kg	275 kg
Dimensions H x W x D (mm)	1100 x 740 x 450	1600 x 750 x 650
HEATED UNIT SECTION		
Installed power	2,0 kW	4,0 kW
Overheat protection	Yes	
VACUUM SECTION		
Installed power	0,37 kW	0,75 kW
Absolute end pressure	-0,02 bar	-0,02 bar
Volume of lube oil	250 cc	450 cc
Desiccant breather	ACL96R	
PUMP SECTION		
Installed power	0,18 kW	0,18 kW & 0,37 kW
Pump volume	1,6 cc	5,8 cc, 8,0 cc
FILTER SECTION		
Filtration	1 or 3 micron	
Filtration material	Glass fibre	

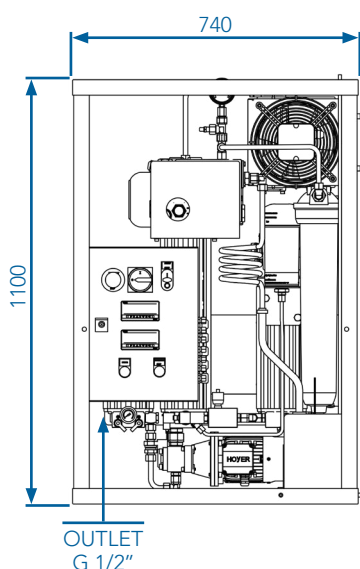

MINI Water VAC

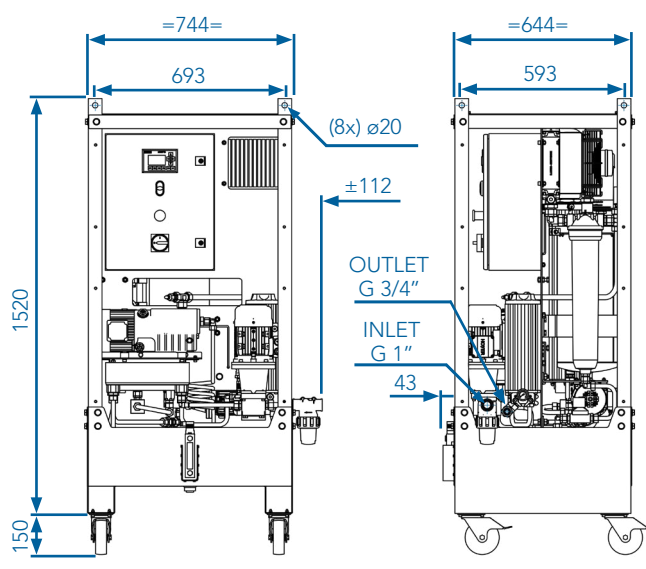
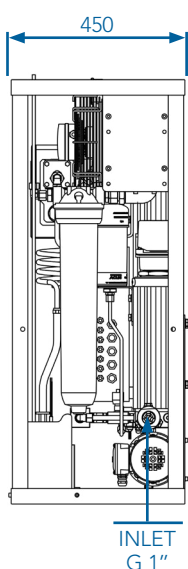

MAXI Water VAC

Ordering Code

VACUUM DEHYDRATION UNITS

YOUR VACUUM DEHYDRATION UNIT ORDERING CODE

TABLE 1	TABLE 2	TABLE 3	TABLE 4	TABLE 5	TABLE 6	TABLE 7	TABLE 8	TABLE 9	TABLE 10	TABLE 11
	1A	30		B	0			0		

TABLE 1 - BASIC CONFIGURATION	CODE
Mini Water Vac	MWV
Maxi Water Vac	MXWV
TABLE 2 - OLU HOUSING CONFIGURATION	CODE
Single housing (single length)	1A
TABLE 3 - LENGTH ELEMENT	CODE
L = 300 mm (standard)	30
TABLE 4 - FILTER MATERIAL	CODE
Glass fiber, 1 micron, $\mu 1 \geq 1000$ (standard)	G1
Glass fiber, 3 micron, $\mu 3 \geq 1000$	G3
TABLE 5 - SEAL MATERIAL	CODE
Buna-N (standard)	B
TABLE 6 - POWER SUPPLY OPTIONS	CODE
230/400 VAC 50 Hz / 3 phase	0
255/460 VAC 60 Hz / 3 phase	
TABLE 7 - PUMP OPTIONS	CODE
Mini Water Vac pump	60
Maxi Water Vac pump	70
TABLE 8 - HEATING ELEMENT	CODE
Mini Water Vac heater	0
Maxi Water Vac heater	1
No heater	2
TABLE 9 - EXTRA FUNCTIONS	CODE
No extra functions	0
Moisture Content Sensor	1
TABLE 10 - OPTIONS	CODE
No options	0
Mobile (wheels, only suitable for Maxi Water Vac)	M
Side panels (only suitable for Maxi Water Vac)	P
Mobile with side panels (only suitable for Maxi Water Vac)	MP
TABLE 11 - PREFILTER	CODE
No prefilter	0
Pre-Filter 100 mesh	1